

# EB 1400

F374, F374-BE, F374-BUR, F374-GRN, F374-ORG, F374-PR, F374-SM, F374-SP

## Symbol Definition

- \* - multiple components to choose from for different models: voltage, size, color, etc.
- + - if you order this item, you may need to order additional items marked with same number of +'s in order to upgrade or complete repair

Find #	Part Description	Part #	Measure	Qty
34	TERMINAL BLOCK - GP 6 X 6 X 8 X 4 QC	02-00157	Each	1
37	CAPACITOR - 40MFD 370V 1.75 DIA ROUND W/MTG BRKT	02-00249	Each	1
	CONNECTOR - CLOSED END CAP 22/18 GA	02-00973	Each	1
2	BLOWER ASSY - MOTORIZED IMPELLER 115V 105W 1650 RPM	02-01515	Each	3
36	CONTACTOR- 1 POLE 24V 20A	02-01516	Each	1
35	TRANSFORMER- ASSY EB 1400	02-01517-01	Each	1
	THERMOSTAT - PROGRAMABLE 24V	02-01518	Each	1
29	CABLE - ASSY THERMOSTAT EB 1400	02-01522	Each	1
	STRAIN RELIEF - LOCKING TAB .385 DIA BLK	02-01544	Each	1
	WASHER - 1/4 RIVET .26 ID X .50 OD X .06 ZP	03-00001	Each	12
	CABLE TIE - 4" NYLON	03-00012	Each	12
41	SCREW - #8 X 1/2 PHIL PH ZP	03-00023	Each	12
53	NUT - #10-24 W/STAR WASHER ZP	03-00038	Each	5
50	WASHER - 5/16 SAE .344 ID X .688 OD .065 ZP	03-00062	Each	8
43	SCREW - #10 X 3/8 SLT SER HWH ZP BLK	03-00079	Each	2
52	SCREW - 5/16-18 X 1 GRADE 5 HH ZP	03-00099	Each	8
57	SCREW- 1/4-20 X 3/8 HWH NYLOC ZP	03-00105	Each	17
	SCREW - 1/4-20 X 1.75 SER HWH ZP	03-00118	Each	12
	GASKET - 1/2 X 1/2 POLYURETHANE PSA	03-00121	Foot	4.83
38	BUSHING - .671 ID X.875 X.41 SPLIT NYLON BLK	03-00126	Each	2
49	MOUNTING PD - NYLON TIE 3/4 X 4 WAY PSA	03-00141	Each	4
	GROMMET- .75 ID X 1.375 OD RUBBER	03-00179	Each	1
61	RIVET - 3/16 X 1/4 AL/AL BLK ANOD	03-00189	Each	8
44	RIVET - 3/16 X 3/8 TRI FOLD AL/AL	03-00207	Each	14
63	RIVET - 3/16 X 1/4 STL/STL BLK	03-00432	Each	16
	CLAMP - 3/8 ID HOSE GRN	03-00471	Each	1
	WASHER - 3/8 USS .43 ID X 1.00 OD X .083 ZP	03-00506	Each	3
56	WASHER - 5/32 RIVET .16 ID X .43 OD X .06 AL	03-01333	Each	4
	BOLT - SHOULDER 5/16-18 X 3/8 X 1.25	03-01336	Each	3
54	SCREW - #10-24 X 1/2 SLT HWH ZP	03-01429	Each	2
58	SCREW - M4 X 6MM PHP ZP	03-01467	Each	12
62	RIVET - SNAP .200 X .200 NYLON BLK	03-01473	Each	6
	CLAMP - HOSE 1/2 BLK	03-01481	Each	1
59	RIVET - 5/32 X 3/8 AL/AL BLK ANOD	03-01482	Each	11
	CAP - BUTTON .62 DIA X .10 POLYETHYLENE BLK	03-01490	Each	1
60	NUT - 10-32 NYLOCK ZP	03-01541	Each	4
45	NUT - 1/2-13 NYLOC	03-01551	Each	2
48	SCREW - #6X3/8 AB PHIL FH ZP	03-01553	Each	4
	LABEL - CAUTION	07-01432	Each	1
	LABEL - PRODUCT EB 1400	07-01586	Each	1
	LABEL - OPERATING INSTRUCTIONS EB 1400	07-01588	Each	1
	LABEL - WARNING DAMP LOCATION W/ MICROBAN TURBODRYERS	07-01590	Each	1
	PACKAGING ASSY - 115V EB 1400	07-01598	Each	1
	POWER CORD ASSY - 14/3 SJTW 5-15P 25 FT	08-00203	Each	1
	NUT - TERMINAL COVER HH	08-00240	Each	1
	WASHER - GASKET 7/32 ID X 9/16 OD RBR	08-00241	Each	1

Find #	Part Description	Part #		Qty
	SPRING - 1-1/16 OD X 1/2 H	08-00242	Each	1
	GASKET - TERMINAL CVR 2-5/16 X 3-9/16 X .036 RBR	08-00243	Each	1
	COVER - TERMINAL 3-14 X 2-1/8 X 1-5/8 PLASTIC	08-00244	Each	1
	GROMMET - .375 ID X 1.125 OD RBR BLACK	08-00248	Each	3
	COMPRESSOR - 115V 10120 BTU	08-00281	Each	1
	COMPRESSOR OVERLOAD - 115V DZ2000	08-00282	Each	1
25	PUMP - DEEPWELL CENTRF 115V 80GPH 6FT CORD	08-00289	Each	1
	FITTING - QUICK DISCONNECT BODY 1/4 HB	08-00302	Each	1
	FITTING - QUICK DISCONNECT INSERT 3/8 BARB	08-00303	Each	1
	INSULATION - CORK TAPE	08-00784	Foot	4.5
7	COIL ASSEMBLY - EVAPORATOR EB 1400	08-01545	Each	1
	COIL ASSEMBLY - CONDENSER EB 1400	08-01546	Each	1
	COVER - POLYETHYLENE FISHER BLU EB 1400	08-01547	Each	1
	MIDDLE PANEL - POLYETHYLENE FISHER BLU EB 1400	08-01548-09	Each	1
	REAR PANEL - POLYETHYLENE FISHER BLU EB 1400	08-01549	Each	1
13	DRIP TRAY - POLYETHYLENE FLINT GRY EB 1400	08-01550	Each	1
	DUCT ADAPTER- POLYETHYLENE FLINT GRY EB 1400	08-01551	Each	2
17	BULKHEAD- GALV STL EB 1400	08-01552	Each	1
18	BASE - GALV STL EB 1400	08-01553	Each	1
19	COVER - ELECTRICAL BOX GALV STL EB 1400	08-01554	Each	1
	SHROUD - ELECTRICAL BOX GALV STL EB 1400	08-01555	Each	1
21	BRACKET - VENTURI GALV STL EB 1400	08-01556	Each	1
22	DAMPER - AIRFLOW GALV STL EB 1400	08-01557	Each	1
16	SHEILD - BLOWER LEAD GALV EB 1400	08-01558	Each	1
	FILTER SHROUD - PC WR BLK EB 1400	08-01559	Each	1
	GRILL - DUCT ADAPTER WR BLK EB 1400	08-01560	Each	3
40	WHEELS - SWIVEL CASTERS EB 1400	08-01562	Each	2
39	WHEELS - RIGID CASTERS EB 1400	08-01563	Each	2
	FILTER - 16.25 X 16.5 X .79 ELECTROSTATIC EB 1400	08-01564	Each	1
	FILTER -19.0 X 17.0 X .39 ELECTROSTATIC GREEN EB 1400	08-01565	Each	2
31	MOUNT - ELECTRICAL COMPONENT GALV STL EB 1400	08-01566	Each	1
	REFRIGERATION LINES 115V EB 1400	08-01567	Each	1
	WIRE HARNESS - EB 1400	08-01568	Each	1
1	VENTURI RING - POLYETHYLENE FLINT GRAY EB 1400	08-01626	Each	1
32	CAPACITOR ASSY - 10MFD 375V BOX	09-00012-01	Each	3
28	DEFROST CONTROL- 115V DZ110	12-00073	Each	1
26	TUBING - 3/8 X 5/8 OD BRAIDED PVC	13-00083	Foot	2
	TUBE - 1/4 ID X 3/8 OD VINYL	15-00195	Foot	40
27	TUBE - 1/2 ID X 3/4 OD VINYL	15-01463	Foot	1
	FITTING - TEE 3/8 X 3/8 X 1/4 COPPER AC/R	18-00764	Each	1
	VALVE - LINE SERVICE 1/4 DIA COPPER	18-00817	Each	1

# EB 1400 Pictorial Drawing

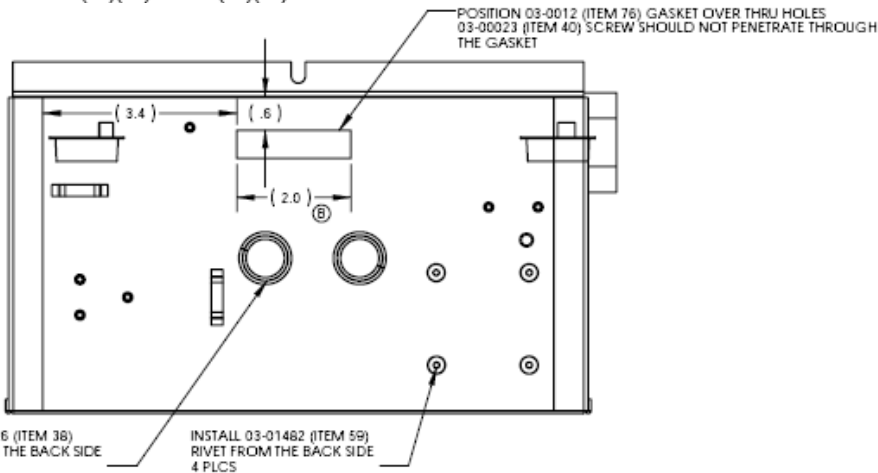
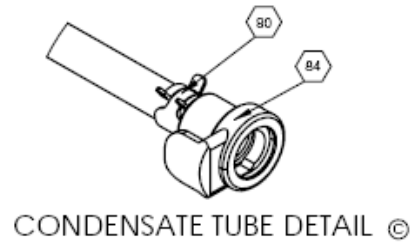
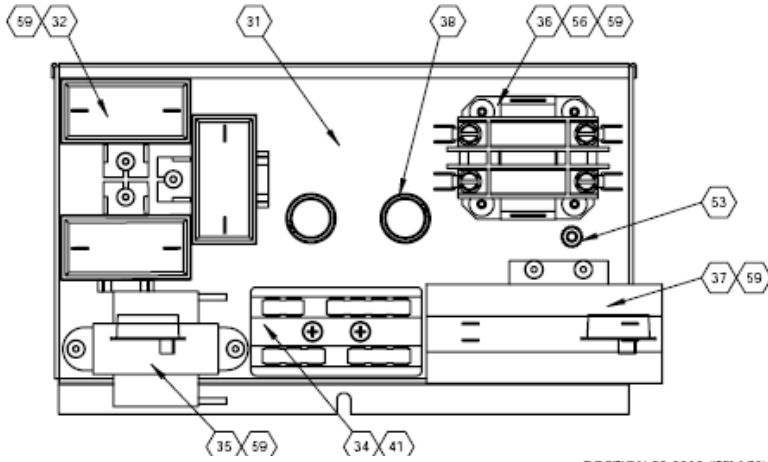

ELECTRICAL BRACKET DETAIL

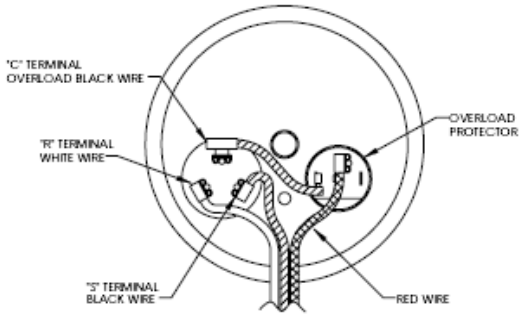

COMPRESSOR WIRING DETAIL

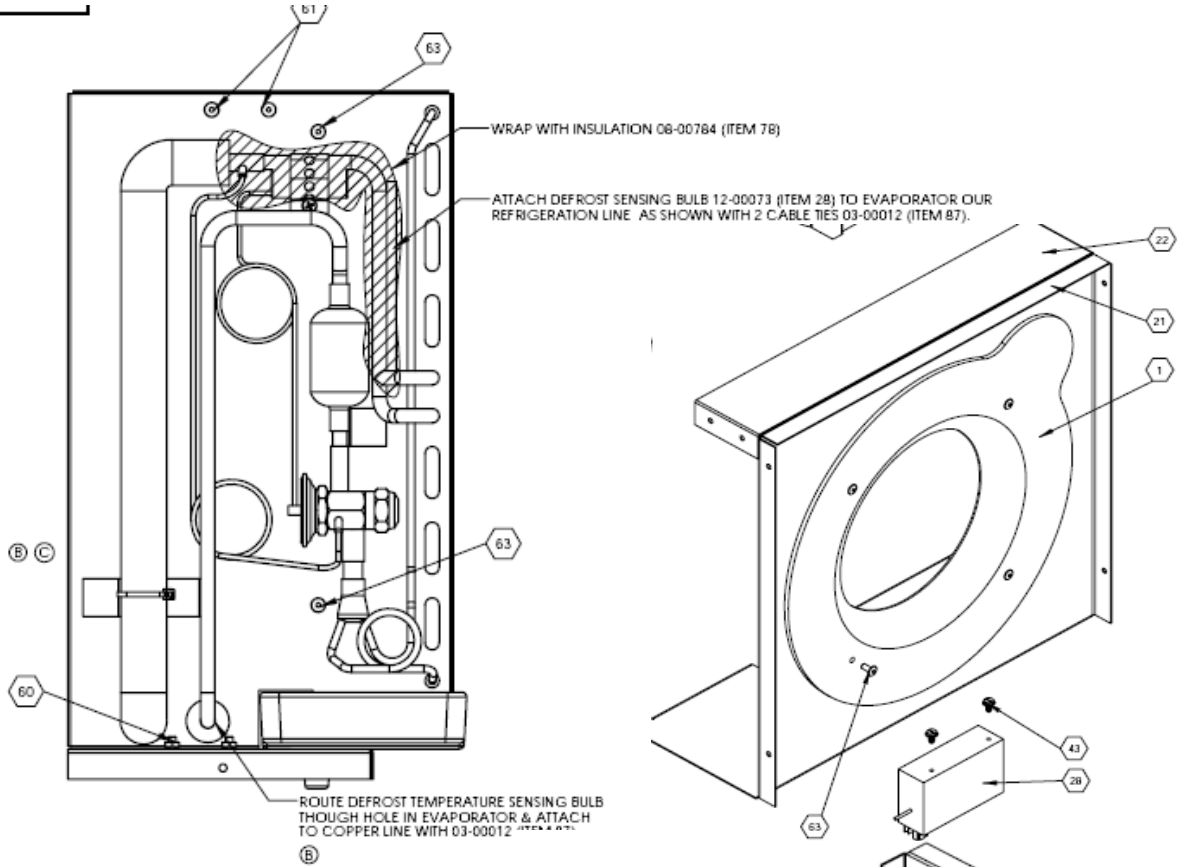

EVAPORATOR DETAIL



